



**Ruckus Wireless®
ZoneFlex® 2741 802.11g
Outdoor Access Point**

Getting Started Guide

Part Number 800-70180-001
Published January 2008

www.ruckuswireless.com

Contents

1	About This Getting Started Guide	1
	Related Documentation	1
	Using ZoneDirector or FlexMaster to Manage the Access Point	1
2	Unpacking the ZoneFlex Access Point	2
	Package Contents	2
	Mounting Kit Contents	2
	Bottom Cover and Accessories	3
3	Before You Begin	4
	Prepare the Required Hardware and Tools	4
	Get to Know the Access Point Features	5
	LED Colors and What They Mean	6
	Perform a Site Survey	9
	Determine the Optimal Mounting Location and Orientation	10
	Become Familiar with the Installation Components	13
	Decide How You Will Supply Power to the Access Point	14
4	Configuring the Access Point.	15
	Configuring for Management by ZoneDirector	15
	What You Will Need	15
	Step 1: Connect the Cables to the Access Point	16
	Step 2: Connect the Access Point to the Same Subnet as ZoneDirector	19
	Step 5: Disconnect the Access Point from the Power Source	19
	Configuring for Standalone Operation or for Management by FlexMaster	20
	What You Will Need	20
	Step 1: Prepare the Administrative Computer	20
	Step 2: Connect the Access Point to the Administrative Computer	22
	Step 3: Log Into the Access Point's Web Interface	25
	Step 4: Configure the Wireless Settings	25
	Step 5: Disconnect the Access Point from the Administrative Computer	29
	Step 6: Restore the Administrative Computer's Network Settings	30

5	Verifying Access Point Operation	30
	Connect the Access Point to the Network	30
	Check the LEDs	31
	Associate a Wireless Client with the Access Point	31
	Check the TR069 Status (FlexMaster Management Only)	32
	Disconnect the Access Point from the Network	32
6	Deploying the Access Point	32
	Step 1: Complete the Power Connections	32
	Step 2: Install the Back Panel Cover	37
	Step 3: Connect the Access Point to the Network	38
7	Attaching the Mounting Brackets	40
	What You Will Need	40
	Step 1: Attach the Static Bracket to the Mounting Surface	40
	Attaching the Bracket to a Flat Surface	40
	Attaching the Bracket to a Pole	44
	Step 2: Attach the Dynamic Bracket to the Access Point	46
8	Mounting the Access Point	47
9	(Optional) Mounting and Connecting the External Antenna	50
10	What to Do Next	53
	Change the Administrative Password	53
	Configure the Security Settings	53
	Read Related Documentation	53

1 About This Getting Started Guide

This *Getting Started Guide* provides information on how to set up the Ruckus Wireless ZoneFlex 2741 802.11g Outdoor Access Point on your network. Topics covered in this guide include installation, basic configuration, and device mounting.

This guide is intended for use by those responsible for installing and setting up network equipment. Consequently, it assumes a basic working knowledge of local area networking, wireless networking, and wireless devices.

Related Documentation

In addition to this guide, each Ruckus Wireless ZoneFlex 2741 802.11g Outdoor Access Point documentation set includes the following:

- **User Guide:** Provides detailed information on how to configure the Access Point. The User Guide is available for download on the Ruckus Wireless Support Web site at: <http://support.ruckuswireless.com/documents>
- **Release Notes:** Provides late-breaking information about the current software release, including new features, enhancements, and known issues. If the information in the Release Notes differs from the information in this guide, follow the instructions in the Release Notes.
- **Online Help:** Accessible from the Access Point's Web interface, the Online Help provides information that helps you configure the device from the Web interface.

Using ZoneDirector or FlexMaster to Manage the Access Point

If you are planning to use either Ruckus Wireless FlexMaster or Ruckus Wireless ZoneDirector to manage the Access Point, this guide describes the required steps that will enable the Access Point to report to and communicate with FlexMaster or ZoneDirector successfully.

- To set up the Access Point for management by FlexMaster, refer to [“\(Optional\) Set the FlexMaster Server Address”](#) on [page 28](#).
- To set up the Access Point for management by ZoneDirector, refer to [“Configuring for Management by ZoneDirector”](#) on [page 15](#).

2 Unpacking the ZoneFlex Access Point

1. Open the Access Point package, and then carefully remove the contents.
2. Return all packing materials to the shipping box, and put the box away in a dry location.
3. Verify that all items listed in [Package Contents](#) below are included in the package. Check each item for damage. If any item is damaged or missing, notify your authorized Ruckus Wireless sales representative.

Package Contents

A complete Access Point package contains all of the items listed below:

- ZoneFlex 2741 Outdoor Access Point
- Box containing the PoE injector (excluded in some SKUs)
- Box containing the power adapter (SW DC48V/0.42A AC100-240V) for the PoE injector (excluded in some SKUs)
- Two-prong plug adapter (for three-prong wall outlet)
- Mounting kit (see ["Mounting Kit Contents"](#) for details)
- Bag containing bottom Access Point cover and related accessories (see ["Bottom Cover and Accessories"](#) for details)
- Service Level Agreement / Limited Warranty Statement
- Regulatory Statement
- This *Getting Started Guide*



WARNING: The Ruckus Wireless PoE injector and power adapter (if supplied with your Access Point) are for indoor use only. Never mount the PoE injector and power adapter outdoor with the Access Point.

Mounting Kit Contents

- Dynamic bracket
- Static bracket
- Steel clamp
- Wall anchors (4 pieces)
- Hex bolts (4 pieces)
- Machine screws (8 pieces)
- Split lock washers (4 pieces)
- Flat washers (4 pieces)

Figure 1. Mounting kit contents

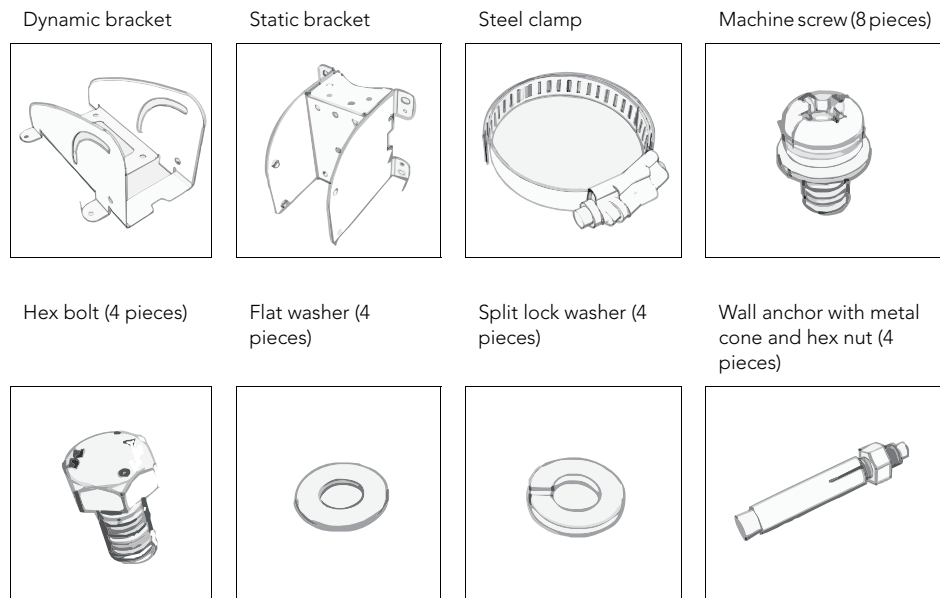

Bottom Cover and Accessories

- Bottom cover of the Access Point
- DC terminal block
- Black solid rubber stoppers (2 pieces)
- Rubber O-rings (1 black and 1 green)
- White P-clip cable clamp (2 pieces)
- Machine screws (2 pieces)
- Machine screws with washers (3 pieces)

Before You Begin

Prepare the Required Hardware and Tools

Figure 2. Mounting kit contents

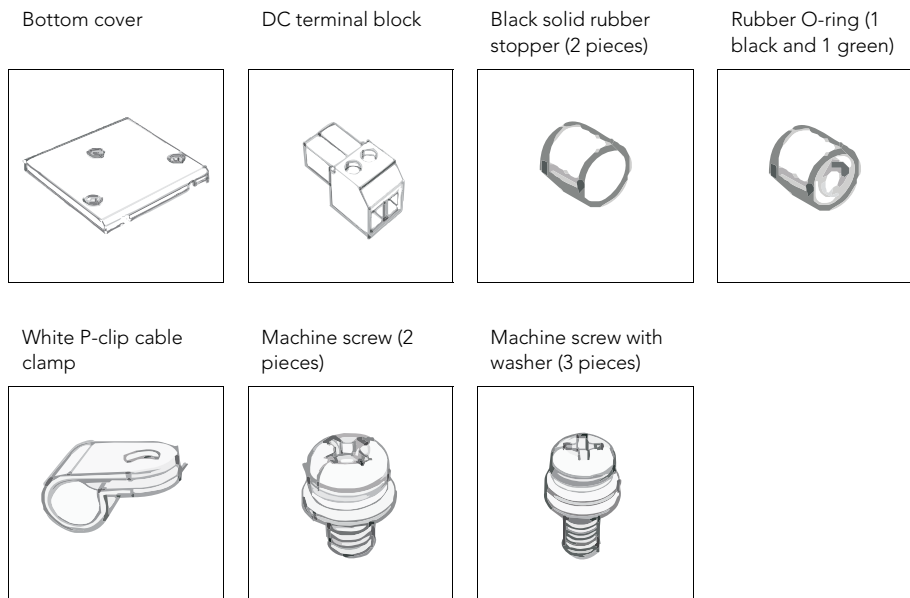

3 Before You Begin

Before installing and setting up the Access Point, Ruckus Wireless recommends that you first complete the following pre-installation tasks.

Prepare the Required Hardware and Tools

You must supply the following tools and equipment:

- A notebook computer running on Windows XP/2000 and installed with one wireless 802.11b/g network card and one Ethernet card
- 6mm flathead screwdriver
- 6mm Phillips screwdriver
- 10mm ratchet wrench
- 3mm Phillips screwdriver (if you will be using DC power)
- Electric drill with 8mm drill bit (if mounting on a flat surface)



NOTE: At the beginning of each procedure, this guide lists the specific tools, accessories, and equipment that you will need to complete the procedure.

Get to Know the Access Point Features

[Figure 3](#) and [Figure 4](#) identify the Access Point features that are relevant to the installation and mounting instructions that this guide provides. Before you begin the installation process, Ruckus Wireless recommends that you become familiar with these features.

Figure 3. Access Point LEDs and bottom connectors

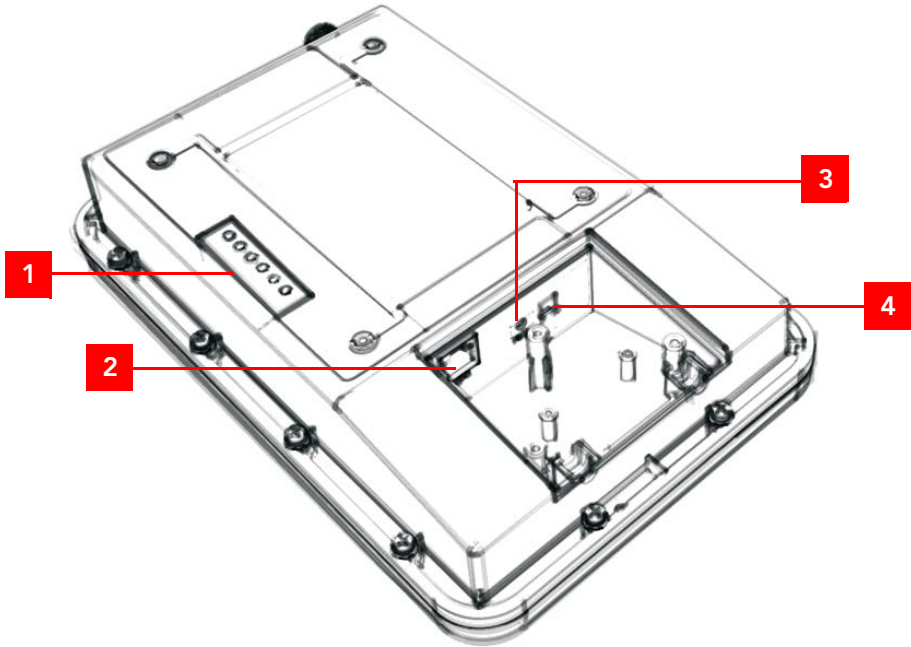

Before You Begin

Get to Know the Access Point Features

Table 1. LEDs and bottom panel connectors

No	Label	Description
1	LEDs	See "LED Colors and What They Mean" below for more information.
2	RJ45	LAN port that supports Power over Ethernet (PoE) and 10/100Mbps network connections
3	Reset	Using a pointed object (for example, a pen), press this button to restart the Access Point or to restore it to factory default settings: <ul style="list-style-type: none">• To restart the Access Point, press the Reset button once.• To restore the Access Point to factory default, press the Reset button for six (6) seconds. <p><i>WARNING: Restoring the Access Point to factory default settings removes all configuration changes that you have made. These include the IP address, password, access control list, and wireless settings. Returning the configuration of these features to their factory default settings may result in network connectivity issues.</i></p>
4	12V DC	In addition to PoE, you can also use direct current or DC (from a battery, for example) to supply power to the Access Point.

LED Colors and What They Mean

Refer to [Table 2](#) below for all possible LED states and what they indicate.

Table 2. LED states and behaviors

LED	Meaning
OPT	Not used in this model
DIR	<ul style="list-style-type: none">• <i>Off</i>: The Access Point is not being managed by ZoneDirector (standalone mode).• <i>Green</i>: The Access Point is being managed by ZoneDirector.• <i>Flashing green</i>: The Access Point is being managed by ZoneDirector, but is currently unable to communicate with ZoneDirector.

Table 2. LED states and behaviors

LED	Meaning
AIR	<ul style="list-style-type: none"> • <i>Green</i>: The Access Point is functioning as a mesh AP (MAP) and the wireless signal to its uplink MAP is <i>good</i> (> 24dbm). • <i>Fast flashing green (two flashes every second)</i>: The Access Point is functioning as a mesh AP (MAP) and the wireless signal to its uplink MAP is <i>poor</i> (< 24dbm). • <i>Slow flashing green (one flash every two seconds)</i>: Mesh networking is enabled, but the Access Point cannot find a mesh uplink. • <i>Off</i>: The Access Point is operating in standalone mode or, if mesh networking is enabled, the Access Point is functioning as a root AP (RAP).
WLAN	<ul style="list-style-type: none"> • <i>Green</i>: The wireless LAN (WLAN) service is up and at least one wireless client is associated with it. If mesh networking is enabled, there are no downlink MAPs connected to this Access Point. • <i>Fast flashing green (two flashes every second)</i>: The WLAN service is up and at least one wireless client is associated with it. Mesh networking is enabled and at least one downlink MAP is connected to this Access Point. • <i>Slow flashing green (one flash every two seconds)</i>: The WLAN service is up, but no wireless clients are currently associated with it. Mesh networking is enabled and at least one downlink MAP is connected to this Access Point. • <i>Off</i>: Either the WLAN is down, or it is up but no wireless clients are currently associated with it. If mesh networking is enabled, there are no downlink MAPs connected to this Access Point.
LAN	<ul style="list-style-type: none"> • <i>Green</i>: The LAN port is connected to a 10/100Mbps device. • <i>Flashing green</i>: Traffic is passing through the LAN port. • <i>Off</i>: The LAN port is not connected to any network device.

Before You Begin

Get to Know the Access Point Features

Table 2. LED states and behaviors

LED	Meaning
PWR	<ul style="list-style-type: none">• <i>Green</i>: The Access Point is connected to a power source.• <i>Off</i>: No power is available, or the Access Point is not connected to a power source.

If you want to extend the range of your wireless network, you can connect an external high gain antenna to the standard N-type radio frequency (RF) antenna connector on the top panel of the Access Point. The antenna must have a gain of less than 9dBi to comply with FCC and CE regulations. For more information, refer to [“\(Optional\) Mounting and Connecting the External Antenna”](#) on [page 50](#).

Figure 4. The antenna connector is protected by a metal cap

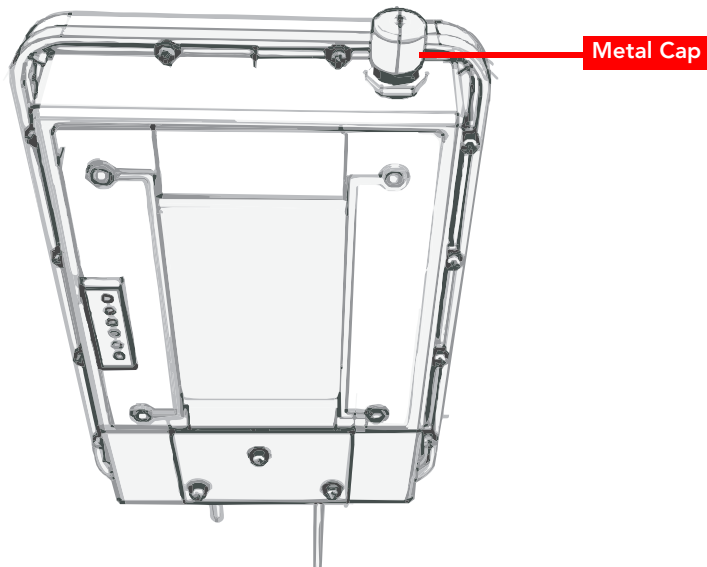

Perform a Site Survey

Before installing the Access Point, perform a site survey to determine the optimal Access Point placement or maximum range, coverage, and network performance. When performing a site survey, consider the following factors:

- *Data rates:* Range is generally inversely proportional to data rates. The maximum radio range is achieved at the lowest workable data rate. Higher data rates will generally be achieved at closer distances.
- *Antenna type and placement:* Proper antenna configuration is a critical factor in maximizing radio range. As a general rule, radio range is increased by mounting the radio higher off of the ground with the Access Point oriented so that the dome is facing down (for recommended orientation examples, refer to [Figure 5](#) on page 10). If you are connecting an external antenna to the Access Point, mount the Access Point so that the external antenna is pointing down.
- *Physical environment:* Clear or open areas provide better radio range than closed or filled areas. The less cluttered the operating environment, the greater the wireless range.
- *Obstructions, building materials, and sources of interference:* Physical obstructions, such as concrete pillars, steel beams, filing cabinets, buildings, or trees, can block or hinder wireless communication. Avoid installing the Access Point in a location where there is an obstruction between sending and receiving devices. A number of machines and electronic devices that emit radio waves – cranes, wireless phones, microwave ovens, satellite dishes – interfere with and block wireless signals. Building materials used in construction also influence radio signal penetration. For example, drywall construction permits greater range than concrete blocks.

For more Access Point placement guidelines, refer to [“Determine the Optimal Mounting Location and Orientation”](#).

Before You Begin

Determine the Optimal Mounting Location and Orientation

Determine the Optimal Mounting Location and Orientation

The location and orientation that you choose for the Access Point play a critical role in the performance of your wireless network. In general, Ruckus Wireless recommends installing the Access Point away from obstructions and sources of interference and ensuring that the Access Point's dome is pointing in the general direction of its wireless clients.

Figure 5. Recommended orientation for maximum horizontal plane coverage

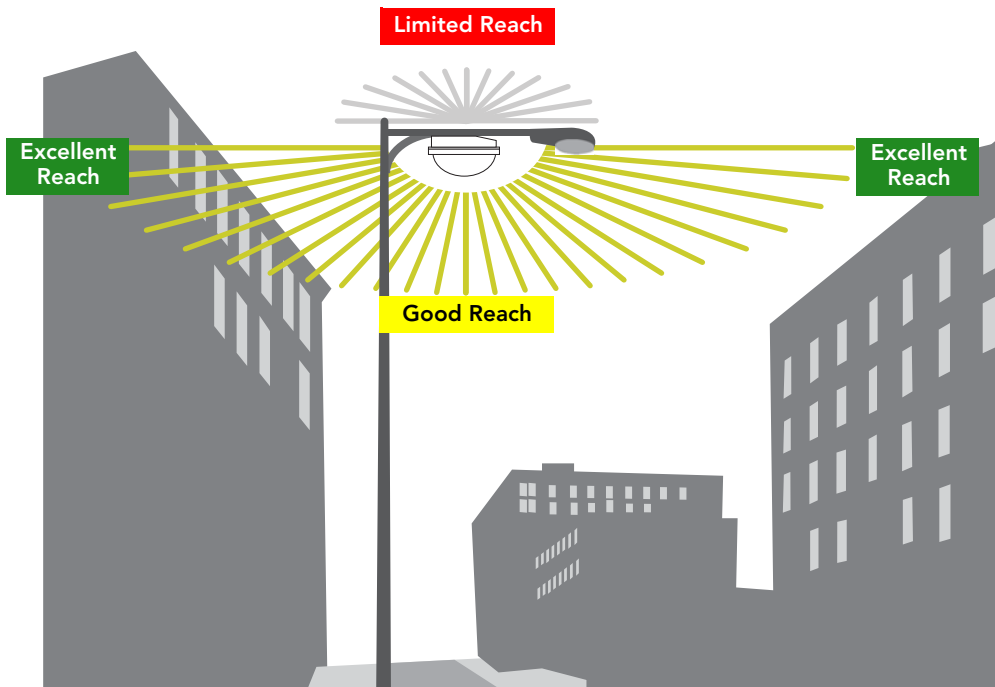
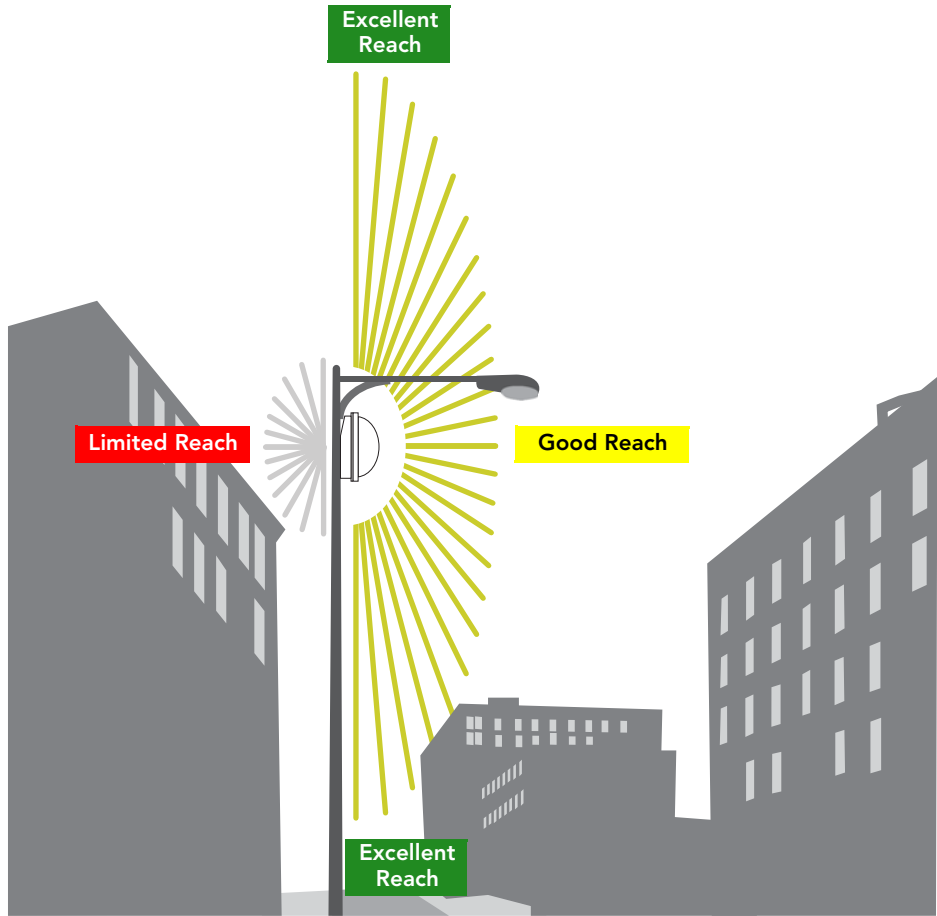

Figure 6. Recommended orientation for maximum vertical plane coverage



Before You Begin

Determine the Optimal Mounting Location and Orientation

Figure 7. Recommended orientation for maximum mesh coverage

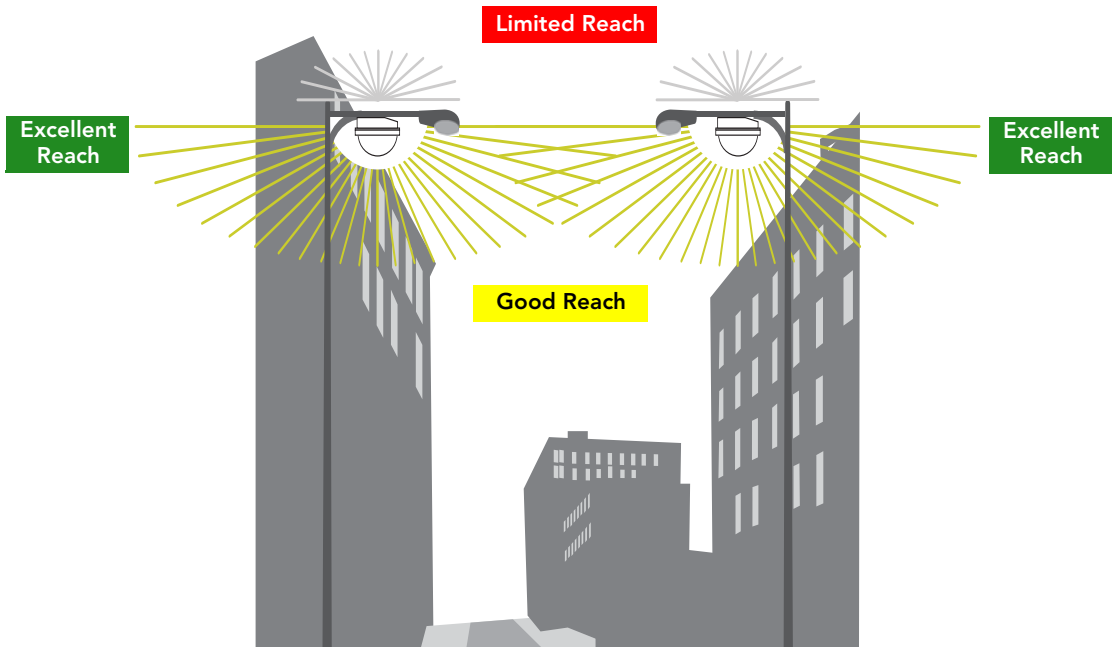

Become Familiar with the Installation Components

The Access Point can be installed in an indoor or outdoor environment, such as an interior wall or ceiling or the exterior roof overhang of a building or a streetlight pole. Refer to [Figure 8](#) for the components involved in a typical installation.

Take note of the components that must be installed indoor and outdoor. The PoE injector and power adapter that are shipped with the Access Point are for indoor use only. Ruckus Wireless also strongly recommends that you form a drip loop on any cable that is connected to devices that are installed outdoor (for example, the Access Point and the Ethernet surge protector).

Figure 8. Typical installation components using both PoE and DC power sources

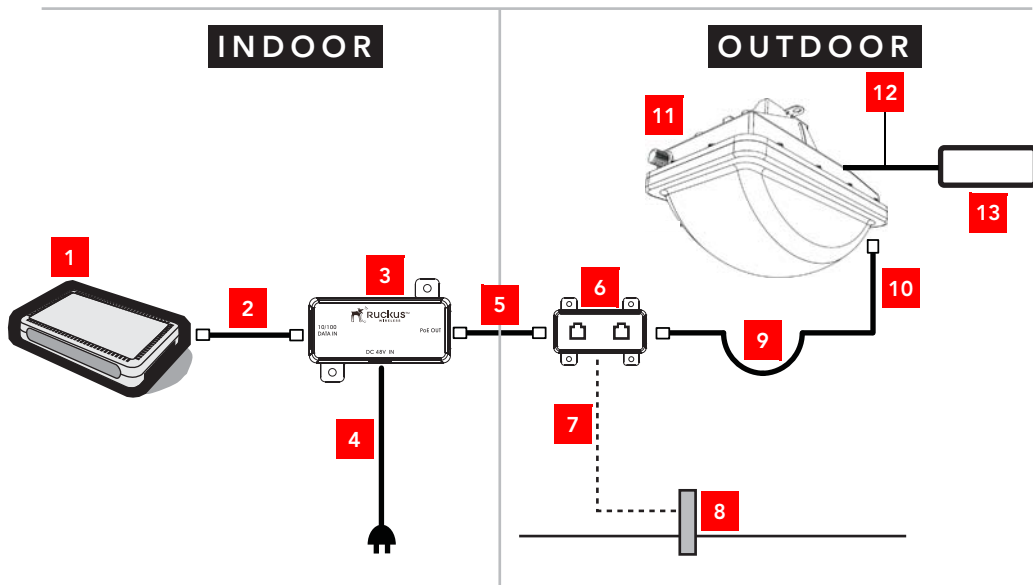

1	Router or switch	8	Ground rod
2	Ethernet (CAT5) cable	9	Drip loop
3	PoE injector	10	Outdoor-rated FTP cable
4	PoE injector power adapter	11	ZoneFlex Outdoor Access Point
5	Ethernet (CAT5) cable	12	DC cable
6	Ethernet surge protector	13	DC battery

Before You Begin

Decide How You Will Supply Power to the Access Point

7 Ground wire



WARNING: Only trained and qualified personnel should be allowed to install, replace, or service this equipment.



WARNING: Installation of this equipment must comply with local and national electrical codes.



CAUTION: Make sure that you form a 3"-5" drip loop in any cable that is attached to the Access Point and Ethernet surge protector. This will prevent water from running along the cable and entering the Access Point, Ethernet surge protector, or the building where the cable terminates.



CAUTION: Be sure that grounding is available and that it meets local and national electrical codes. For additional lightning protection, use lightning rods and lightning arrestors.



WARNING: The Ruckus Wireless PoE injector (if supplied with your Access Point) is for indoor use only. Never mount the PoE injector outdoor with the Access Point.



NOTE: If the power outlet in your installation environment is three-pronged, use the two-prong plug adapter that is shipped with the Access Point.

Decide How You Will Supply Power to the Access Point

The Access Point supports Power over Ethernet (PoE) and 12 VC DC power and can be connected to both power sources at the same time. If you connect the Access Point to both PoE and DC power sources at the same time, it will use PoE as the primary power source and DC power as the backup power source.

4 Configuring the Access Point

The procedure for completing the Access Point's essential configuration depends on whether you want it to be managed by either ZoneDirector or FlexMaster or to operate as a standalone access point. Refer to the section that is relevant to your deployment:

- [Configuring for Management by ZoneDirector](#)
- [Configuring for Standalone Operation or for Management by FlexMaster](#)

Configuring for Management by ZoneDirector

If ZoneDirector is installed on the network, you can configure the Access Point for management by ZoneDirector. Simply connect the Access Point to same Layer 2 subnet as ZoneDirector. When the Access Point starts up, it will discover and register with ZoneDirector automatically.



NOTE: In addition to using Layer 2 auto discovery to enable the Access Point to register with ZoneDirector, you can also use DHCP Option 43 or DNS. For more information, refer to the *ZoneDirector User Guide*.



CAUTION: If you use this method, make sure that you do not change the IP address of ZoneDirector after the AP discovers and registers with it. If you change the ZoneDirector IP address, the AP will no longer be able to communicate with it and will be unable to rediscover it.

Before starting this procedure, check the back panel of the Access Point (above the recess where the bottom connectors are located), and then write down the MAC address of the Access Point. You will need the MAC address to identify the Access Point on the ZoneDirector Web interface.

What You Will Need

Before starting with the configuration task, make sure that you have the following requirements ready:

- A computer from which you can access the ZoneDirector Web interface
- Mozilla Firefox 2.0 (or later) or Microsoft Internet Explorer 6.0 (or later) installed on the administrative computer
- One 5.6mm-6.0mm (outside diameter) Cat5e foil screened twisted pair (FTP) solid cable
- One Ethernet cable

Configuring the Access Point

Configuring for Management by ZoneDirector

- PoE injector (if not supplied with the Access Point, you can purchase a third party 802.3af-compliant PoE injector or switch)
- 6mm Phillips screwdriver

If you are planning to power the Access Point using a 12v DC connection, you will also need the following:

- One 3.1mm-3.3mm UL1185 (80°, 300V) single shielded DC cable
- 12v DC, 1A DC power source (for example, a battery)
- 3mm Phillips screwdriver

Step 1: Connect the Cables to the Access Point

The procedure for connecting cables to the Access Point depends on the power source that you will be using. You can do one of the following:

- [Use Power Over Ethernet](#)
- [Use DC Power](#)



NOTE: You only need to connect one type of power source at this point, even if you are planning to use both PoE and DC power in your final deployment.

Use Power Over Ethernet

1. Take out the PoE injector and the power adapter from the Access Point package.
2. Obtain two Ethernet cables.
3. Connect one end of one Ethernet cable to the **PoE Out** port on the PoE injector, and then connect the other end to the **RJ45** port on the Access Point.
4. Connect one end of the other Ethernet cable to the **10/100 DATA IN** port on the PoE injector.
5. Connect the power jack to the **DC 48V IN** connector on the PoE injector, and then plug the power adapter to a power source. Verify that the **PWR** LED on the back of the Access Point is steady green.



NOTE: If the power outlet in your installation environment is three-pronged, use the two-prong plug adapter that is shipped with the Access Point.

Figure 9. Connect the Ethernet cables and power adapter to the PoE injector

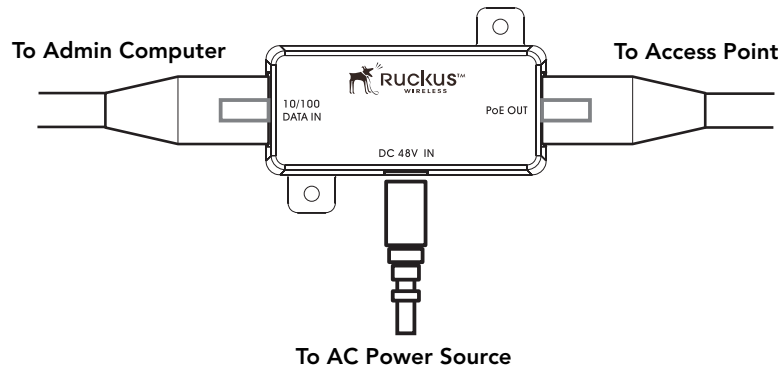

You have completed connecting the Access Point to the administrative computer and to a PoE power source.

Use DC Power

To use DC to power the Access Point, you need to connect a DC cable (not supplied with the Access Point) to the DC terminal block.

1. Connect one end of an Ethernet cable to the **RJ45** port on the Access Point, and then connect the other end to the administrative computer's Ethernet port.
2. Take out the DC terminal block from the small plastic bag that contains the bottom cover of the Access Point.
3. Connect the DC cable's ground wire to V- terminal. If you are looking at the terminal block with the wiring terminal screws on top, the V- terminal is on the *left side*.
4. Connect the DC cable's +12v DC wire to the V+ terminal. If you are looking at the terminal block with the wiring terminal screws on top, the V+ terminal is on the *right side*.

Configuring the Access Point

Configuring for Management by ZoneDirector

Figure 10. Connect the ground wire to the V- terminal and the +12v DC wire to the V+ terminal

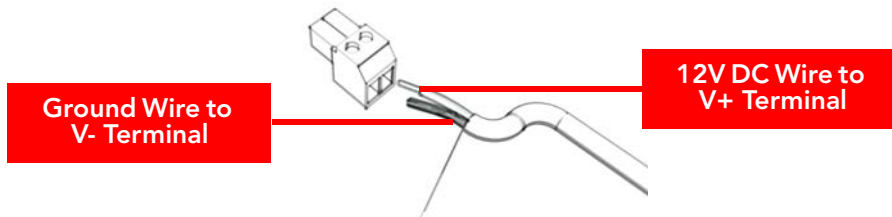

5. Using a 3mm Phillips screw, tighten the wiring terminal screws. Screw torque value must be 4kg-5kg.
6. Connect the DC terminal block to the **12V DC** port on the Access Point.

Figure 11. Connect the DC terminal block to the 12V DC port

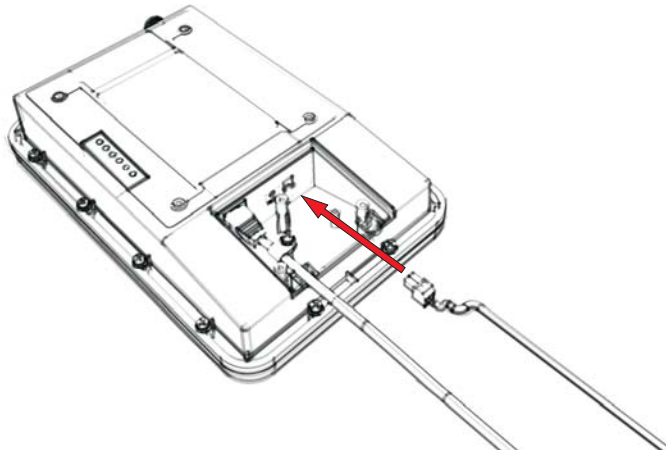

7. Connect the DC cable to a DC power source (for example, a battery).
You have completed connecting the Access Point to the administrative computer and to a DC power source.

Step 2: Connect the Access Point to the Same Subnet as ZoneDirector

1. Verify that the Access Point is powered on.
1. Connect the Access Point to the same Layer 2 subnet as ZoneDirector. The same Layer 2 subnet means that there should not be any router between the Access Point and ZoneDirector.
2. Log into ZoneDirector, and then go to the **Monitor > Access Points** page.
3. Look for the MAC address of the Access Point, and then check its **Status** column.
 - If automatic approval is enabled, the Status column should show **Connected**.
 - If automatic approval is disabled, click the **Allow** link that is on the same row as the Access Point's MAC address. This allows the Access Point to register with ZoneDirector.

When the Status column shows **Connected**, this indicates that the Access Point has successfully registered with ZoneDirector and that it can now be moved to its destination Layer 2 or Layer 3 network.

Step 5: Disconnect the Access Point from the Power Source

1. Disconnect the Access Point from the power source (either from the PoE injector or DC power source).
2. Verify that the **PWR** LED on the back of the Access Point is off.
3. Continue to ["Attaching the Mounting Brackets"](#) on [page 40](#).

Configuring for Standalone Operation or for Management by FlexMaster

What You Will Need

Before starting with the configuration task, make sure that you have the following requirements ready:

- An administrative computer (notebook computer) running on Microsoft Windows Vista/XP/2000
- Mozilla Firefox 2.0 (or later) or Microsoft Internet Explorer 6.0 (or later) installed on the administrative computer
- One 5.6mm-6.0mm (outside diameter) Cat5e foil screened twisted pair (FTP) solid cable
- One Ethernet cable
- PoE injector (if not supplied with the Access Point, you can purchase a third party 802.3af-compliant PoE injector or switch)
- 6mm Phillips screwdriver

If you are planning to power the Access Point using a 12v DC connection, you will also need the following:

- One 3.1mm-3.3mm UL1185 (80°, 300V) single shielded DC cable
- 12v DC, 1A DC power source (for example, a battery)
- 3mm Phillips screwdriver

Step 1: Prepare the Administrative Computer



NOTE: The following procedure is applicable if the administrative computer is running on Windows XP or Windows 2000. If you are using a different operating system, refer to the documentation that was shipped with your operating system for information on how to modify the computer's IP address settings.

1. On your Windows XP or Windows 2000 computer, open the **Network Connections** (or **Network and Dial-up Connections**) control panel according to how the Start menu is set up:
 - On Windows XP, click **Start > Control Panel > Network Connections**.
 - On Windows 2000, click **Start > Settings > Network Connections**.
2. When the Network Connections window appears, right-click the icon for Local Area Connection, and then click **Properties**.



NOTE: Make sure that you configure the Local Area Connection properties, not the Wireless Network Connection properties.

3. When the **Local Area Connection Properties** dialog box appears, select **Internet Protocol (TCP/IP)** from the scrolling list, and then click **Properties**. The **Internet Protocol (TCP/IP) Properties** dialog box appears.
4. Write down all of the currently active network settings. You will need this information later when you restore your computer to its current network configuration.
5. Click **Use the following IP address**, and then configure the IP address settings with the values listed in [Table 3](#). For a sample configuration, refer to [Figure 12](#).

Table 3. Configure your computer's IP address settings

IP address	192 . 168 . 0 . 22 (or any address in the 192.168.0.x network—with the exception of 192 . 168 . 0 . 1, which is already used by the Access Point)
Subnet mask	255 . 255 . 255 . 0
Default gateway	192 . 168 . 0 . 1
Preferred DNS server	192 . 168 . 0 . 1

You can leave the **Alternate DNS server** box blank.

6. Click **OK** to save your changes and close the TCP/IP Properties dialog box.
7. Click **OK** again to close the Local Area Connection Properties dialog box.

Windows saves the IP address settings that you have configured.

Configuring the Access Point

Configuring for Standalone Operation or for Management by FlexMaster

Figure 12. Sample configuration in the Internet Protocol (TCP/IP) Properties dialog box

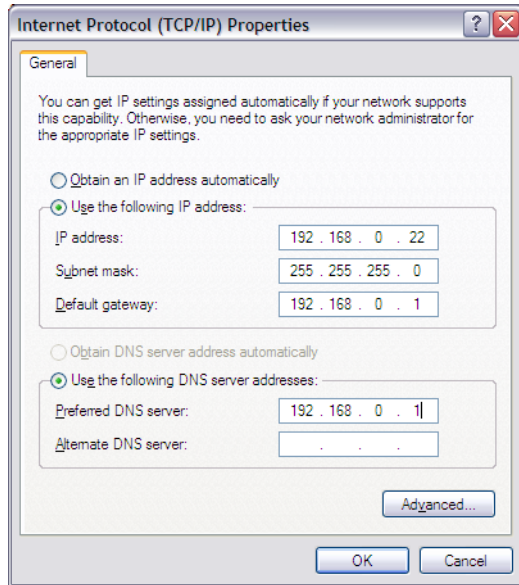

Step 2: Connect the Access Point to the Administrative Computer

The procedure for connecting the Access Point to the administrative computer depends on the power source that you will be using. You can do one of the following:

- [Use Power Over Ethernet](#)
- [Use DC Power](#)



NOTE: You only need to connect one type of power source at this point, even if you are planning to use both PoE and DC power in your final deployment.

Use Power Over Ethernet

1. Take out the PoE injector and the power adapter from the Access Point package.
2. Obtain two Ethernet cables.
3. Connect one end of one Ethernet cable to the **PoE Out** port on the PoE injector, and then connect the other end to the **RJ45** port on the Access Point.
4. Connect one end of the other Ethernet cable to the **10/100 DATA IN** port on the PoE injector.

5. Connect the power jack to the **DC 48V IN** connector on the PoE injector, and then plug the power adapter to a power source. Verify that the **PWR** LED on the back of the Access Point is steady green.



NOTE: If the power outlet in your installation environment is three-pronged, use the two-prong plug adapter that is shipped with the Access Point.

Figure 13. Connect the Ethernet cables and power adapter to the PoE injector

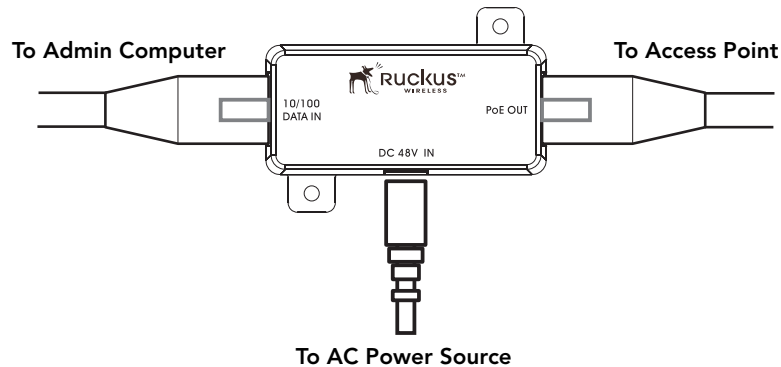

You have completed connecting the Access Point to the administrative computer and to a PoE power source.

Use DC Power

To use DC to power the Access Point, you need to connect a DC cable (not supplied with the Access Point) to the DC terminal block.

1. Connect one end of an Ethernet cable to the **RJ45** port on the Access Point, and then connect the other end to the administrative computer's Ethernet port.
2. Take out the DC terminal block from the small plastic bag that contains the bottom cover of the Access Point.
3. Connect the DC cable's ground wire to V- terminal. If you are looking at the terminal block with the wiring terminal screws on top, the V- terminal is on the *left side*.
4. Connect the DC cable's +12v DC wire to the V+ terminal. If you are looking at the terminal block with the wiring terminal screws on top, the V+ terminal is on the *right side*.

Configuring the Access Point

Configuring for Standalone Operation or for Management by FlexMaster

Figure 14. Connect the ground wire to the V- terminal and the +12v DC wire to the V+ terminal

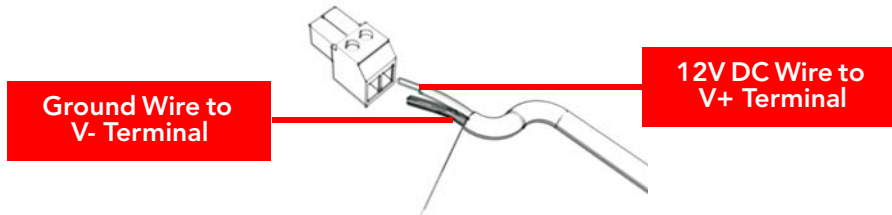

5. Using a 3mm Phillips screw, tighten the wiring terminal screws. Screw torque value must be 4kg-5kg.
6. Connect the DC terminal block to the **12V DC** port on the Access Point.

Figure 15. Connect the DC terminal block to the 12V DC port

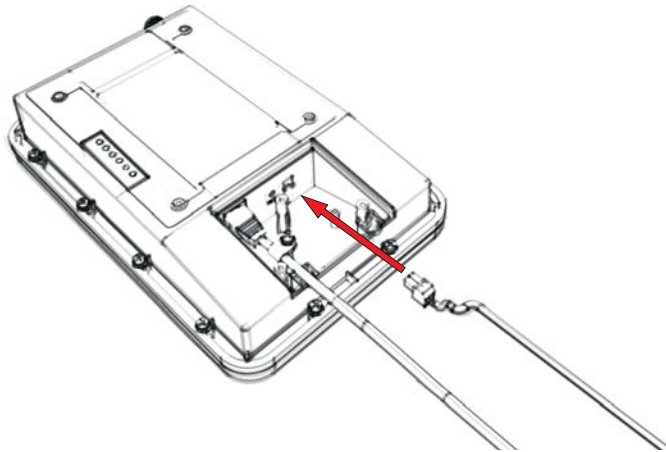

7. Connect the DC cable to a DC power source (for example, a battery).
You have completed connecting the Access Point to the administrative computer and to a DC power source.

Step 3: Log Into the Access Point's Web Interface

1. On the administrative computer, open a Web browser window.
2. In the address or location bar, type the following address:
`https://192.168.0.1`
3. Press <Enter> on the keyboard to connect to the Access Point's Web interface. A security alert message appears.
4. Click **Yes** or **OK** (depending on the browser) to continue. The Access Point's login page appears.

Figure 16. The ZoneFlex Access Point login page



5. In **User name**, type `super`.
6. In **Password**, type `sp-admin`.
7. Click **Log In**. The Web interface appears, displaying the Device page.
8. Continue to ["Step 4: Configure the Wireless Settings"](#) below.

Step 4: Configure the Wireless Settings

To complete this step, you will need to configure the settings on the **Common** tab and at least one **Wireless #** tab. These are the essential wireless settings that will enable wireless devices on the network to associate with the Access Point.

For your reference, the default wireless settings on the Access Point are listed in [Table 4](#).

Configuring the Access Point

Configuring for Standalone Operation or for Management by FlexMaster

Table 4. Default wireless settings

Setting	Default Value
SSID (network name)	Wireless 1 to Wireless 8 (8 WLANs)
Encryption (security)	Disabled on all WLANs
Default management IP address	192.168.0.1

Configure Common Wireless Settings

1. On the left menu of the Web interface, click **Configuration** > **Wireless**. The Common page appears.
2. Verify that the common wireless settings are configured as listed in [Table 5](#).

Table 5. Common wireless configuration

Setting	Recommended Value
Wireless Mode	Auto-select
Channel	SmartSelect
Country Code	<ul style="list-style-type: none">• If you purchased the Access Point in the United States, this value is fixed to United States at the factory and is not user configurable.• If you purchased the Access Point outside the United States, verify that the value is set to your country or region. Selecting the correct country code ensures that the Access Point uses only the radio channels allowed in your country or region.

3. If you made any changes to the **Common** tab, click **Update Settings**.
4. Continue to ["Configure Wireless # Settings"](#) below.

Figure 17. The Configuration > Wireless > Common tab

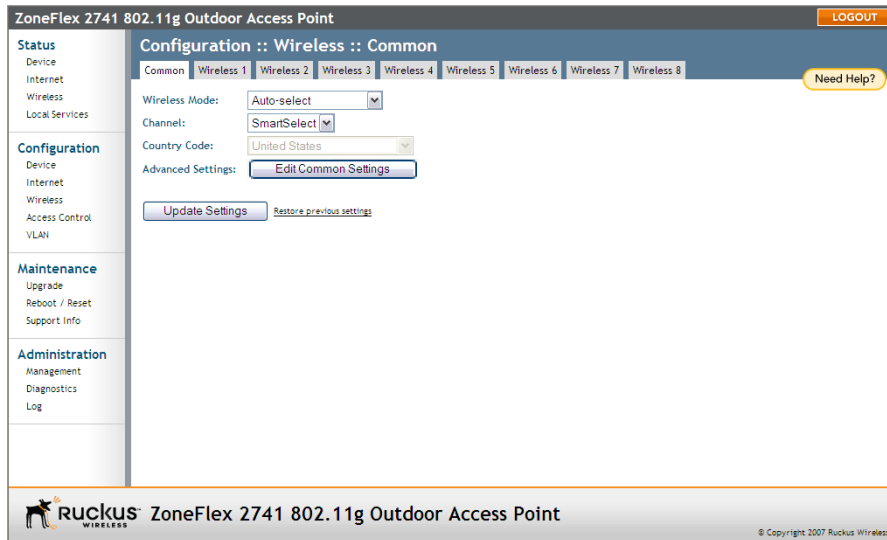

Configure Wireless # Settings

1. Click one of the **Wireless #** tabs.
2. In **Wireless Availability**, click **Enabled**.
3. In **Broadcast SSID**, click **Enabled**.
4. Clear the **SSID** box, and then type a unique and descriptive name that you want to call this wireless network.

For example, you can type `Ruckus Wireless AP`. This SSID is the name that will help users identify this wireless network in their wireless network connection application.



NOTE: You may also configure other wireless settings on this and other **Wireless #** tabs (in addition to the settings described above), although it is not necessary for completing the Access Point installation.

5. Click **Update Settings**.

You have completed configuring the basic wireless settings of the Access Point.

Configuring the Access Point

Configuring for Standalone Operation or for Management by FlexMaster

Figure 18. The Configuration > Wireless > Wireless 1 tab

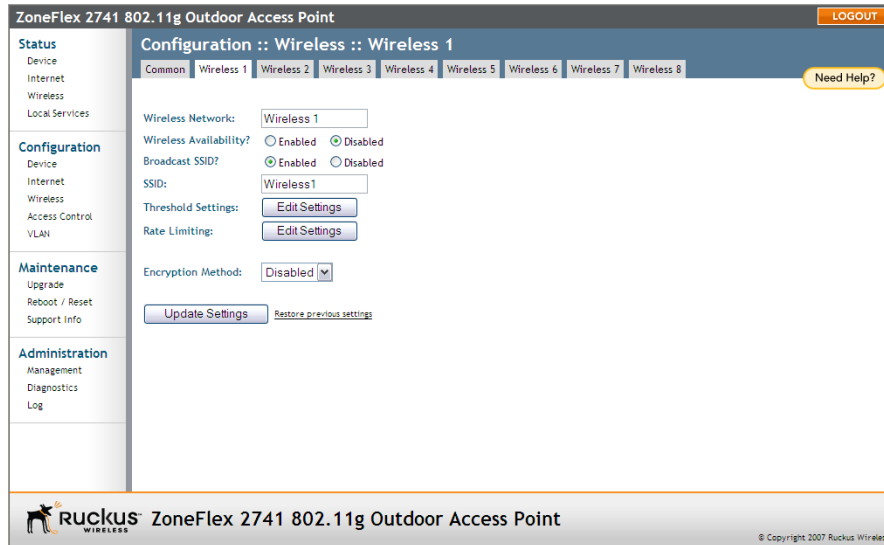

(Optional) Set the FlexMaster Server Address

If you have a FlexMaster server installed on the network and you intend to use FlexMaster to manage the Access Point, you can set the FlexMaster server address at this point. Before starting this procedure, make sure you obtain the correct FlexMaster server URL.



NOTE: In addition to setting the FlexMaster server URL manually on the Access Point, you can also use DHCP Option 43 or DNS to point the Access Point to the FlexMaster server. For more information, refer to the *FlexMaster User Guide*.

1. On the menu, click **Administration > Management**.
2. Scroll down the page to the **TR069 / SNMP Management Choice** section.
3. Verify that the **Auto** option is selected.
4. In **FlexMaster Server URL**, type the URL of the FlexMaster server on the network. You can use either `http` or `https` to connect to the URL and include either the host name or IP address of the FlexMaster server in the URL. The following are examples of valid FlexMaster server URLs:

```
http://flexmaster/intune/server
https://flexmaster/intune/server
http://192.168.20.1/intune/server
https://192.168.20.1/intune/server
```

5. Click **Update Settings** to save your changes.

You have completed setting the FlexMaster server address on the Access Point.

Figure 19. Type the FlexMaster server URL

The screenshot shows the configuration page for a ZoneFlex 2741 802.11g Outdoor Access Point. The interface is divided into several sections: Status, Configuration, Maintenance, and Administration. The 'Configuration' section is active, showing settings for TR069 / SNMP Management Choice, DHCP Discovery, and FlexMaster Server URL. The 'FlexMaster Server URL' field is highlighted with a red box and contains the text 'http://flexmaster/intune/server'. Other fields include 'Digest-authentication Username' (001392-zf10003104), 'Digest-authentication password' (zf10003104-001392), 'Contact FlexMaster every' (15 min), and 'Associated-Clients Monitoring Mode' (Disabled). The 'TR069 Status' section shows 'Currently using: (not contacted yet)', 'Last attempted contact: (not contacted yet)', 'Last successful contact: (not contacted yet)', and 'Current time: Wed Nov 5 08:22:00 2008 (UTC)'. The 'Update settings' button is visible at the bottom of the configuration section.



NOTE: Instructions on how to verify that the Access Point and FlexMaster can communicate with each other are provided in [“Check the TR069 Status \(FlexMaster Management Only\)”](#) on [page 32](#).

Step 5: Disconnect the Access Point from the Administrative Computer

1. Disconnect the Access Point from the power source (either from the PoE injector or DC power source).
2. Verify that the **PWR** LED on the back of the Access Point is off.
3. Disconnect the Ethernet cable from the administrative computer's Ethernet port.

Step 6: Restore the Administrative Computer's Network Settings

1. On your Windows XP or Windows 2000 computer, open the **Network Connections** (or **Network and Dial-up Connections**) control panel according to how the Start menu is set up:
 - On Windows XP, click **Start > Control Panel > Network Connections**.
 - On Windows 2000, click **Start > Settings > Network Connections**.
2. When the Network Connections window appears, right-click the icon for **Local Area Connection**, and then click **Properties**.
3. When the **Local Area Connection Properties** dialog box appears, select **Internet Protocol (TCP/IP)** from the scrolling list, and then click **Properties**. The **TCP/IP Properties** dialog box appears.
4. Restore the computer's network settings by typing the original IP address settings in the **TCP/IP Properties** dialog box.
5. On the **TCP/IP Properties** dialog box, click **OK** to close it.
6. Click **OK** again to close the **Local Area Connection Properties** dialog box.

You are now ready to connect the Access Point to your network.

5 Verifying Access Point Operation

Before mounting the unit, Ruckus Wireless strongly recommends that you verify that the Access Point is operating correctly. To do this, you will need to connect the Access Point to your live network temporarily and make sure that the network connection works and that wireless clients are able to associate with the Access Point and connect to your network and the Internet.



NOTE: The network and power connections that you will be making in this step are temporary. You can perform these verification tasks indoor.

Connect the Access Point to the Network

1. Connect the Ethernet cable from the **RJ45** port on the Access Point to your network's router or switch.
2. Reconnect the Access Point to your preferred power source:
 - If you are using PoE, connect the power adapter to an AC power source.
 - If you are using DC power, connect the DC cable to a DC power source.

You have completed connecting the Access Point to your live network. Perform the tasks described in the following sections to verify that the Access Point is operating normally.

Check the LEDs

Perform a spot-check using the LEDs to verify that the Access Point is operating normally. If the Access Point is operating normally and your wireless client was able to associate with it:

- The **PWR** LED is green.
- The **LAN** LED is green, and if traffic is passing through, it flashes green. Open a Web browser window, type `www.ruckuswireless.com` in the address bar, and then press <Enter>. The **LAN** LED should flash green as your wireless client connects to the Ruckus Wireless Web site through the Access Point.
- The **WLAN** LED is green. This indicates that at least one wireless client is connected to the Access Point's WLAN service.
- If you do not have Ruckus Wireless ZoneDirector on the network, the **DIR** LED is off. This indicates that the Access Point is operating in standalone mode. If there is a ZoneDirector device on the network, the **DIR** LED is green.

Associate a Wireless Client with the Access Point

1. On the administrative computer, verify that the wireless interface is enabled. On Windows XP, click **All Programs > Connect To > Wireless Network Connection** to enable the wireless interface.
2. In the system tray, right-click the  (Wireless Network Connection) icon, and then click **View Available Wireless Networks**.
3. In the list of available wireless network, click the network with the same SSID as you configured in "[Configure Wireless # Settings](#)" on [page 27](#). For example, if you set the SSID to `Ruckus Wireless AP`, click the wireless network named **Ruckus Wireless AP**.
4. Click **Connect**.

Your wireless client connects to the wireless network. After the wireless client connects to the wireless network successfully, the wireless client icon in the system tray changes to .

Deploying the Access Point

Check the TR069 Status (FlexMaster Management Only)

Check the TR069 Status (FlexMaster Management Only)

If you configured the Access Point to report to a FlexMaster server on the network, make sure you verify that it can successfully communicate with the FlexMaster server. You can do this by checking the TR069 status on the Access Point's Web interface.

1. Log in to the Access Point's Web interface.
2. Go to the **Administration > Management** page.
3. Scroll down to the **TR069 Status** section.
4. Check the value for **Last successful contact**. If it shows a date in green, this indicates that the Access Point was able successfully communicate with FlexMaster.

Disconnect the Access Point from the Network

1. Disconnect the Access Point from the power source.
2. Disconnect the Ethernet cable that runs to the Access Point's RJ45 port from your network's router or switch.

You are now ready to deploy the Access Point to its permanent mounting location.

6 Deploying the Access Point

In this step, you will connect the Access Point to the network from its mounting location.

Step 1: Complete the Power Connections

The Access Point supports both PoE and DC power and it can be connected to both power sources at the same time. If you want use both power sources, complete the power connections in this step.



NOTE: If you want to use PoE only or DC power only (not both), you do not need to complete this step. You already configured one power connection earlier when you completed ["Step 2: Connect the Access Point to the Administrative Computer"](#) on [page 22](#).

For instructions on completing the power connection that you need to make, refer to the procedures below:

- [Use Power Over Ethernet](#)
- [Use DC Power](#)

Use Power Over Ethernet

1. Take out the PoE injector and the power adapter from the Access Point package.
2. Obtain three Ethernet cables. Two of these Ethernet cables must be outdoor-rated.
3. Connect one end of the *outdoor-rated* Ethernet cable to the **RJ45** port on the Access Point, and then connect the other end to a port on the Ethernet surge suppressor.
4. Connect one end of another Ethernet cable to another port on the Ethernet surge suppressor, and then connect the other end to the **PoE Out** port on the PoE injector.



NOTE: Install the Ethernet surge protector between the Access Point and the PoE injector and use two outdoor-rated Ethernet cables for the connections. See [Figure 25](#) for an example.

5. Connect one end of the other Ethernet cable to the **LAN** port on the PoE injector, and then connect the other end to your network.
6. Connect the power jack to the **DC 48V IN** connector on the PoE injector.



WARNING: Do not apply power to the Access Point at this point. You should connect the Access Point to a power source only after you finish connecting all other components in ["Step 3: Connect the Access Point to the Network"](#) on [page 38](#).

Figure 20. Connect the Ethernet cables and power adapter to the PoE injector

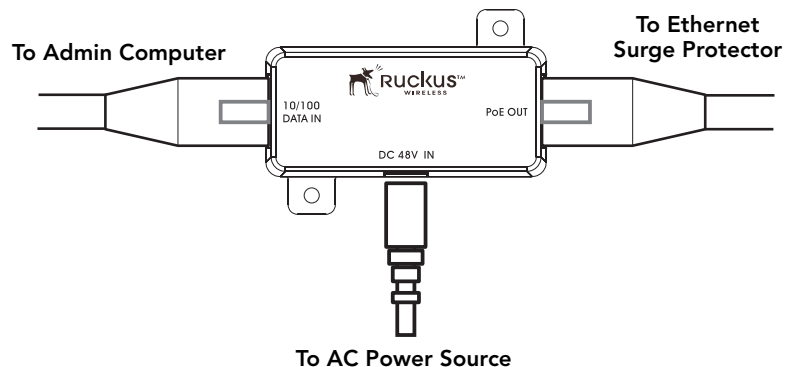

7. Wrap the white P-clip cable clamp around the Ethernet cable, and then fasten it to the Access Point chassis using one of the short machine screws supplied with the Access Point.

Deploying the Access Point

Step 1: Complete the Power Connections

8. Wrap the black rubber O-ring around the Ethernet cable, and then place the wrapped section into the left cable groove. The black rubber O-ring can support a cable with 5.6mm to 6.0mm outside diameter.

Figure 21. Install the white P-clip clamp and the black rubber O-ring

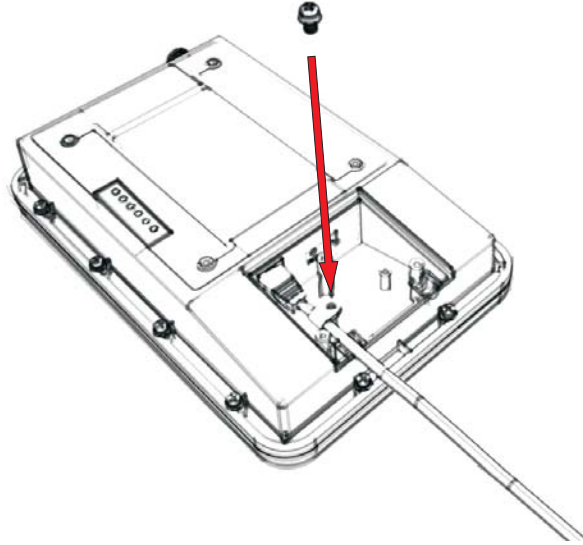

You have completed setting up the PoE power connection.

Use DC Power

To use DC to power the Access Point, you need to connect a DC cable (not supplied with the Access Point) to the DC terminal block.

1. Take out the DC terminal block from the small plastic bag that contains the bottom cover of the Access Point.
2. Connect the DC cable's ground wire to V- terminal. If you are looking at the terminal block with the wiring terminal screws on top, the V- terminal is on the *left side*.
3. Connect the DC cable's +12v DC wire to the V+ terminal. If you are looking at the terminal block with the wiring terminal screws on top, the V+ terminal is on the *right side*.

Figure 22. *Connect the ground wire to the V- terminal and the +12v DC wire to the V+ terminal*

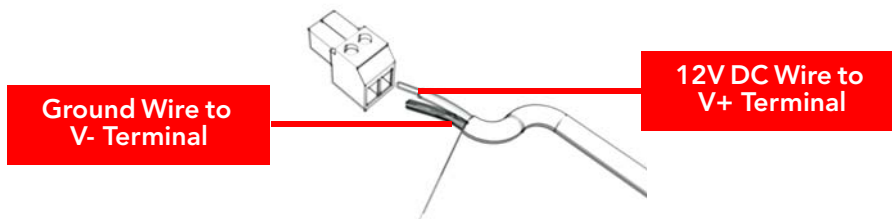

4. Using a 3mm Phillips screw, tighten the wiring terminal screws. Screw torque value must be 4kg-5kg.
5. Connect the DC terminal block to the **12V DC** port on the Access Point.



WARNING: Do not apply power to the Access Point at this point. You should connect the Access Point to a power source only after you finish connecting all other components in ["Step 3: Connect the Access Point to the Network"](#) on [page 38](#).

Deploying the Access Point

Step 1: Complete the Power Connections

Figure 23. Install the white P-clip clamp and the black rubber O-ring

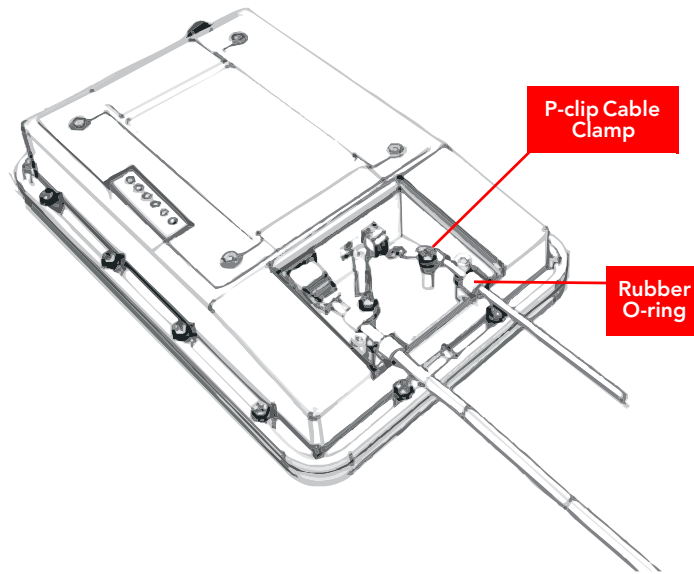

CAUTION: If you are not connecting the DC cable to the DC terminal block, make sure you cover the right cable groove with one of the supplied solid rubber stoppers.

You have completed setting up the DC power connection.

Step 2: Install the Back Panel Cover

Place the bottom cover of the Access Point onto the bottom section, and then fasten it using the three machine screws that are supplied with the Access Point.



CAUTION: Before installing the bottom cover, verify that the perimeter rubber gasket on the underside of the cover is clear of debris.

Figure 24. Fasten the bottom cover using three machine screws

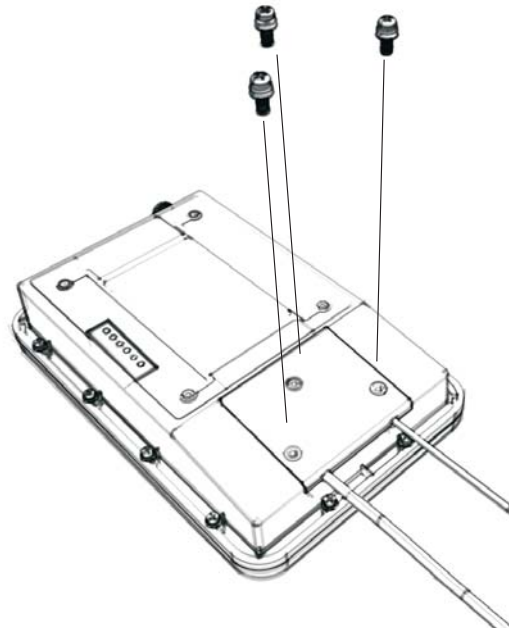

Deploying the Access Point

Step 3: Connect the Access Point to the Network

Step 3: Connect the Access Point to the Network

In this step, you will connect the Access Point from its mounting location to the network. The connections required for your installation depend on the power sources that you are using. [Figure 25](#) shows an example of the connections required for a typical installation that uses both PoE and DC power as power sources.

Figure 25. Typical installation components using both PoE and DC power sources

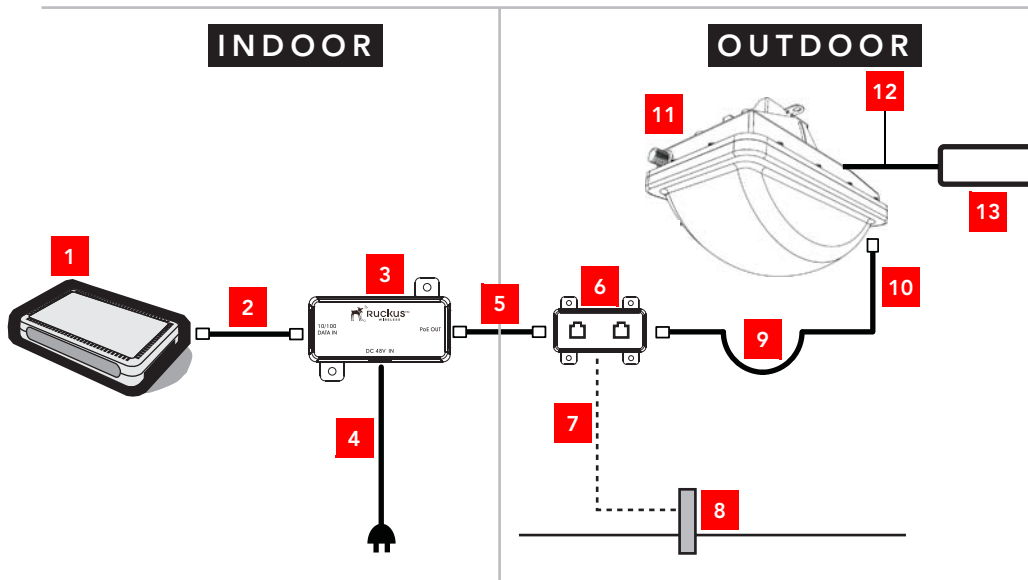

1	Router or switch	8	Ground rod
2	Ethernet (CAT5) cable	9	Drip loop
3	PoE injector	10	Outdoor-rated FTP cable
4	PoE injector power adapter	11	ZoneFlex Outdoor Access Point
5	Ethernet (CAT5) cable	12	DC cable
6	Ethernet surge protector	13	DC battery
7	Ground wire		



WARNING: Do not apply power to the Access Point until you finish connecting all other components.

1. Take the Access Point to its mounting location.
2. Verify that the Cat5e FTP cable (outdoor-rated) from the Access Point is long enough to reach the PoE injector that is installed indoor.
3. Install an Ethernet surge protector between the Access Point and the PoE injector where the cable enters the building (as shown in [Figure 25](#)). Use outdoor-rated Ethernet cables for the connections.
4. Create a drip loop in any cable that is attached to the Access Point and Ethernet surge protector. This will prevent water from running along the cable and entering the Access Point, Ethernet surge protector, or the building where the cable terminates.
5. Verify that the **RJ45** port on the AP is connected to the **PoE OUT** port on the PoE injector.
6. Connect the Ethernet cable from the **10/100 DATA IN** port on PoE injector to your network router or switch.
7. Apply power to the Access Point.
 - If you are using PoE, plug the power adapter to an AC power source.
 - If you are using DC power, connect the DC cable to a DC power source.



NOTE: If the power outlet in your installation environment is three-pronged, use the two-prong plug adapter that is shipped with the Access Point.

8. Verify that the **PWR** LED on the back of the Access Point is steady green.
9. Continue to [“Attaching the Mounting Brackets”](#).

7 Attaching the Mounting Brackets

What You Will Need

To complete this procedure, you will need the following items:

- Static bracket
- Dynamic bracket
- Wall anchors
- Flat washers
- Hex nuts
- 10mm ratchet wrench

If you are mounting the Access Point on a flat surface, you will also need an electric drill with an 8mm drill bit.

If you are mounting the Access Point on a pipe or pole, you will also need the following:

- A 30mm to 60 mm (1.18 in. to 2.36 in.) pipe or pole
- Steel clamp
- 10mm flathead screwdriver

Step 1: Attach the Static Bracket to the Mounting Surface

The procedure for attaching the bracket to the mounting surface depends on whether you are mounting the Access Point to a flat surface or a pole.

- [Attaching the Bracket to a Flat Surface](#)
- [Attaching the Bracket to a Pole](#)

Attaching the Bracket to a Flat Surface



WARNING: Ruckus Wireless strongly recommends that you wear eye protection before drilling holes on the mounting surface.



NOTE: The wall anchors that are supplied with the Access Point are for mounting on *solid masonry walls* only. If you are mounting the Access Point on other materials (for example, drywall, wood, or hollow cinder block), you will need the appropriate types of wall anchors. Check your local hardware store for options.

Attaching the Mounting Brackets

Step 1: Attach the Static Bracket to the Mounting Surface

1. Place the static bracket at the exact location on the mounting surface where you want to mount it.
2. Use the static bracket as a template to mark the locations of the mounting holes on the four mounting tabs.

Figure 26. Mark the locations of the mounting holes

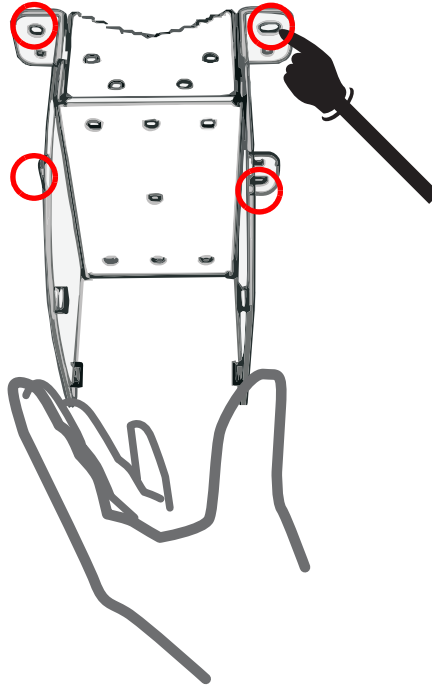

3. Remove the static bracket from the mounting surface.
4. Drill an 8mm-diameter hole with a depth of 36mm-38mm into each of the four markings that you made on the mounting surface.
5. Insert a wall anchor (with the unthreaded part first) into each of the holes that you drilled.
6. Place a metal cone on each wall anchor, and then place a flat washer on top of the metal cone.

Attaching the Mounting Brackets

Step 1: Attach the Static Bracket to the Mounting Surface

Figure 27. *Insert a wall anchor into each hole that you drilled, and then place a metal cone and a flat washer on top*

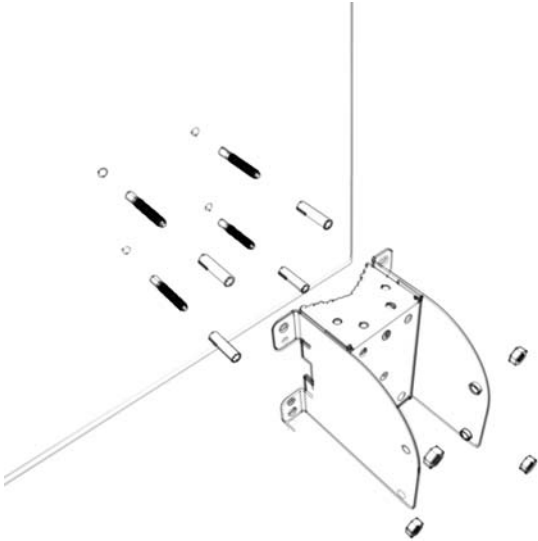

Attaching the Mounting Brackets

Step 1: Attach the Static Bracket to the Mounting Surface

7. Align the four screw holes on the bracket with the wall anchors that you inserted earlier.

Figure 28. *Align the screw holes on the bracket with the wall anchors*

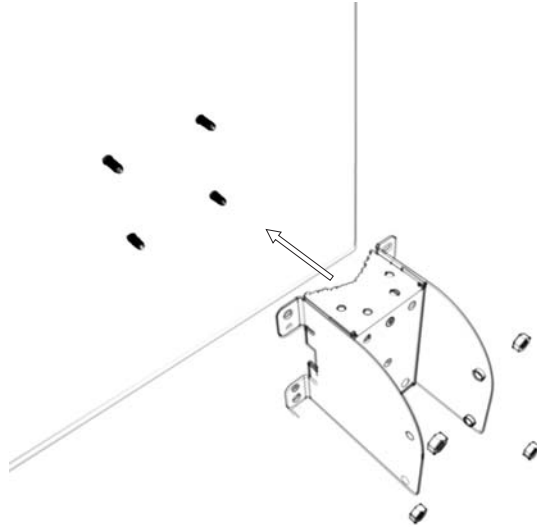

8. Use four hex nuts to attach the bracket to the mounting surface.

Figure 29. *Use four hex nuts to attach the bracket to the surface*

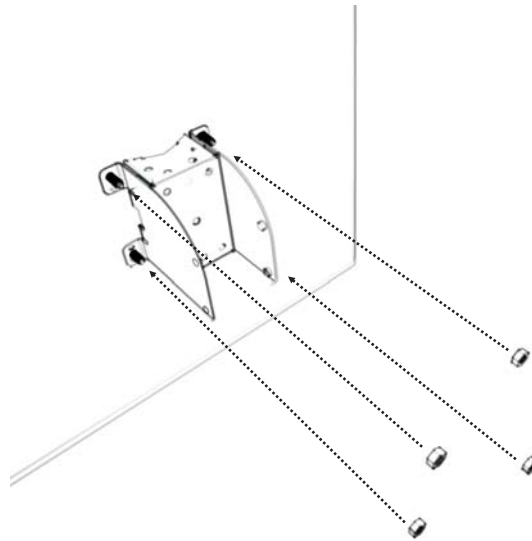

Attaching the Mounting Brackets

Step 1: Attach the Static Bracket to the Mounting Surface

9. Using a 10mm open-end wrench, tighten the nuts to secure the bracket to the mounting surface. Screw torque value must be 4kg-5kg. As you tighten the nuts, the metal cones that are built into the wall anchors will expand and lock the wall anchors into place.
10. Continue to [“Step 2: Attach the Dynamic Bracket to the Access Point”](#).

Attaching the Bracket to a Pole

The Access Point can be mounted vertically or horizontally on a 30mm to 60mm (1.18 in. to 2.36 in.) pole.

1. Insert the open end of the steel clamp into the two tabs on the bracket.

Figure 30. Insert the steel clamp into the two tabs on the bracket

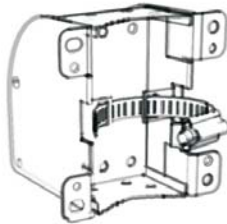

Attaching the Mounting Brackets

Step 1: Attach the Static Bracket to the Mounting Surface

2. Use the clamp to attach the bracket to the pole.

Figure 31. Use the clamp to attach the bracket to the pole

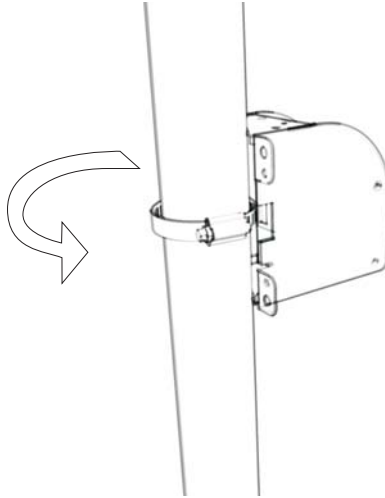

3. Using a 10mm flathead screwdriver, tighten the clamp lock to secure the bracket to the pole. Screw torque value must be 4kg-5kg.

Figure 32. Tighten the clamp lock to secure the bracket

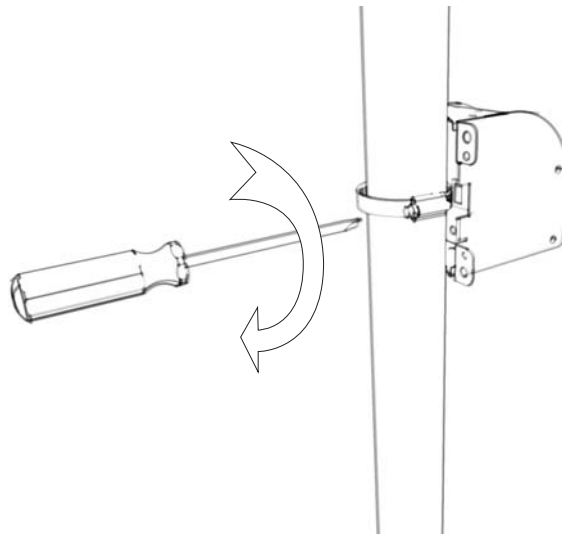

4. Continue to ["Step 2: Attach the Dynamic Bracket to the Access Point"](#).

Attaching the Mounting Brackets

Step 2: Attach the Dynamic Bracket to the Access Point

Step 2: Attach the Dynamic Bracket to the Access Point

1. Place the dynamic bracket onto the flat side of the Access Point so that the four screw holes on the bracket align with the four screw holes on the Access Point. Make sure that the shorter end of the mounting bracket is on the same side as the antenna connector.
2. Insert four machine screws (supplied with the Access Point) into the screw holes on the bracket.

Figure 33. Insert four machine screws into the screw holes

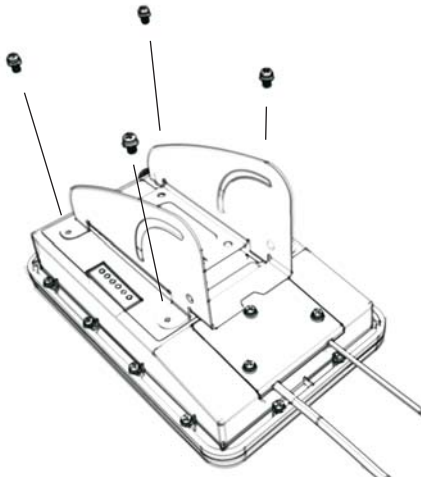

3. Using a 6mm Phillips screwdriver, tighten the four machine screws to fasten the bracket to the Access Point. Screw torque value must be 4kg-5kg.



4. Continue to [“Deploying the Access Point”](#) on [page 32](#).

8 Mounting the Access Point

To mount the Access Point, you will need to join the two mounting brackets that you attached earlier to the device and the mounting surface. For this procedure, you will need the following items:

- Hex bolts
- 10mm ratchet wrench



NOTE: Figures in this section show mounting on a vertical pole. Procedures for mounting on a flat surface or horizontal surface are similar.

To join the two mounting brackets together:

1. Join the two brackets as shown in [Figure 34](#). Make sure that:
 - The dynamic bracket (attached to the Access Point) encloses the static bracket (attached to the mounting surface).
 - *(For mounting on a vertical pole)* The side of the Access Point with the antenna connector is at the bottom, especially if you are planning to install an external antenna.
 - *(For mounting on a horizontal pole)* The side of the Access Point with the **RJ45** port is toward the building. This will help ensure that the Ethernet cable or DC cable will not create any signal interference for the antenna.

Mounting the Access Point

Step 2: Attach the Dynamic Bracket to the Access Point

Figure 34. Joining the two brackets in a vertical pole installation

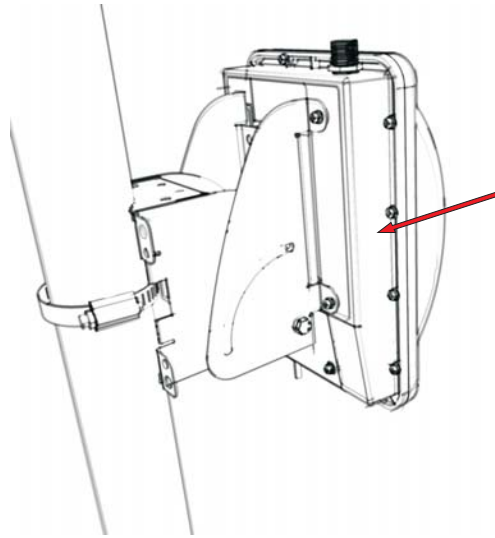

2. Align the mounting holes on the dynamic bracket with the mounting holes on the static bracket.
3. Place a split lock washer, and then a flat washer onto a hex bolt. Then insert the hex bolt into one of the mounting holes.



NOTE: Make sure the screw-washer assembly is in correct order. The split-lock washer should be in the middle and the flat washer should touch the bracket.

4. Repeat Step 3 for each of the mounting holes. There are four mounting holes on the bracket – two on each side.

Figure 35. Insert hex bolts into the mounting holes

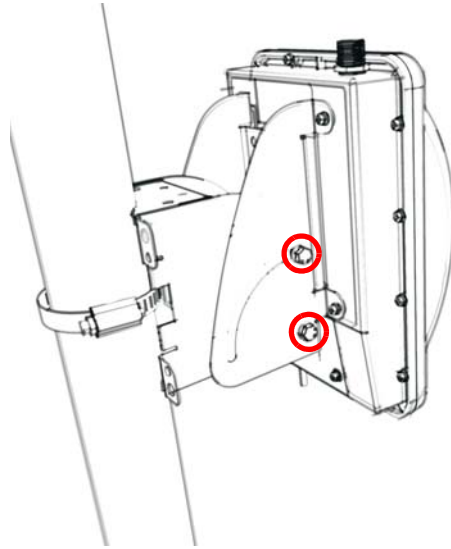

5. Finger tighten the hex bolts.
6. Adjust the Access Point to your desired orientation.



NOTE: If you have not yet determined the optimal orientation for your Access Point, refer to [“Determine the Optimal Mounting Location and Orientation”](#) on [page 10](#) for orientation guidelines.

7. Using a 10mm ratchet wrench, tighten the hex bolts to fix the Access Point’s orientation. Screw torque value must be 4kg-5kg.

You have completed mounting the Access Point.

9 (Optional) Mounting and Connecting the External Antenna

If you want to extend the range of your wireless network, you can connect a 2.4GHz 9dBi (or lower) external antenna to the standard N-type female connector on the Access Point.



WARNING: Only trained and qualified personnel should be allowed to install, replace, or service this equipment.



WARNING: Before connecting the antenna to the Access Point, make sure that you disconnect the Access Point from the power source.

1. Disconnect the Access Point from the power source.
2. Unscrew the metal cap that protects the antenna connector. Place the metal cap in a safe place, in case you need it later.
3. Connect the antenna to the standard N-type female antenna connector.

If the antenna comes with an RF coaxial cable (for example, a patch antenna), do the following:

- a. Physically mount the antenna on your desired location, preferably on the same supporting mounting structure as the Access Point.
- b. Connect the RF coaxial cable to the standard N-type female connector on the Access Point.

(Optional) Mounting and Connecting the External Antenna

Step 2: Attach the Dynamic Bracket to the Access Point

Figure 36. Connect the RF coaxial cable to the standard N-type female connector on the Access Point.

To Patch Antenna

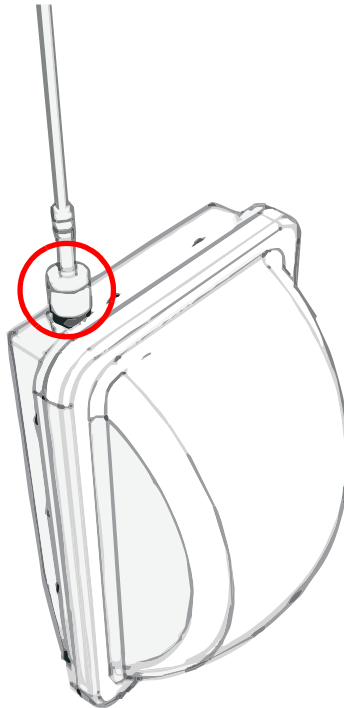

If the antenna comes with a standard N-type male connector for direct connection (for example, an omnidirectional antenna), connect the standard N-type male connector to the standard N-type female connector on the Access Point.

(Optional) Mounting and Connecting the External Antenna

Step 2: Attach the Dynamic Bracket to the Access Point

Figure 37. Connect the standard N-type male connector to the standard N-type female connector on the Access Point

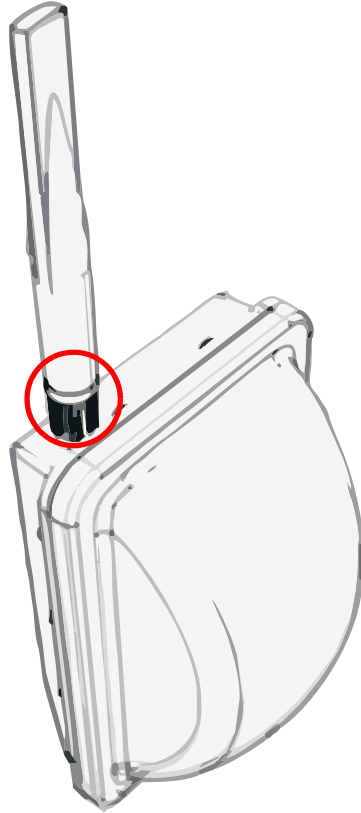

4. Apply weatherproofing tape to the antenna connector to help prevent water from entering the connector.
5. Reconnect the Access Point to the power source.



CAUTION: If you are not connecting an external antenna to the standard N-type antenna interface on the Access Point, make sure that the metal cap remains installed and securely fastened to protect the interface from elements, such as water or dirt.

You have completed connecting the external antenna to the Access Point.

10 What to Do Next

The following are some of the post-installation tasks that Ruckus Wireless recommends. Refer to the *ZoneFlex 2741 802.11g Outdoor Access Point User Guide* for more information on configuring and managing the Access Point.

Change the Administrative Password

Management access to the Web interface of the Access Point is controlled through administrative user name and password. As soon as you complete the Access Point setup, make sure you log on to the Access Point's Web interface and change the default administrative user name and password. This will help prevent unauthorized users from logging in to the Access Point's Web interface and changing the access point settings to compromise your network.

Configure the Security Settings

Unlike wired networks, anyone with a compatible wireless adapter can receive wireless data transmissions from your network well beyond your walls. To prevent unauthorized users from entering your wireless network and accessing your computers and files, Ruckus Wireless strongly recommends enabling and configuring wireless security on the Access Point. The Access Point supports several types of encryption and authentication methods to help prevent unauthorized access to your wireless network.

Read Related Documentation

If you are using FlexMaster or ZoneDirector to manage the Access Point, make sure you read the accompanying documentation to learn how to configure and manage the Access Point from the FlexMaster and ZoneDirector Web interface.

The latest versions of Ruckus Wireless product documentation are available for download on the Ruckus Wireless Support Web site at:

<http://support.ruckuswireless.com/documents>

What to Do Next

Read Related Documentation